

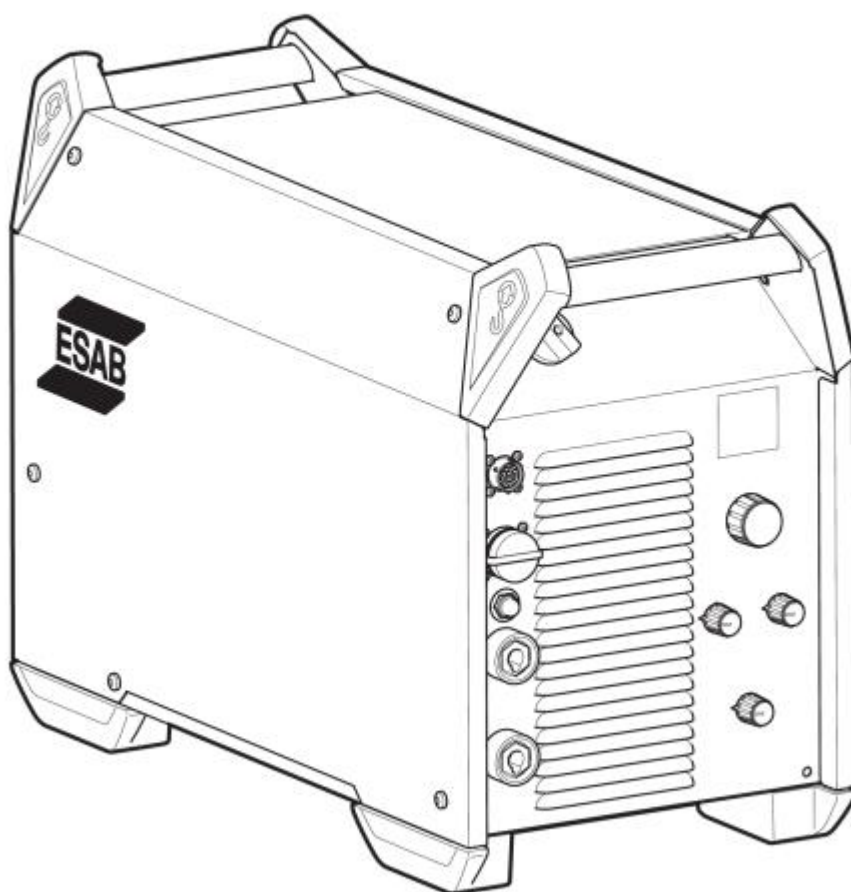

Warrior™ 400i CC/CV

Warrior™ 500i CC/CV

CE version



Spare parts list

Ordering no.	Product
0465 350 883	Warrior 500i CC/CV, 380-415 V
0465 350 884	Warrior 400i CC/CV, 380-415 V
0465 350 885	Warrior 500i CC/CV, VRD 415 V
0465 350 886	Warrior 400i CC/CV, VRD 415 V

Spare parts are to be ordered through the nearest ESAB agency. Kindly indicate type of unit, serial number, denominations and ordering numbers according to the spare parts list.

Maintenance and repair work should be performed by an experienced person, and electrical work only by a trained electrician. Use only recommended spare parts.

SPARE PARTS	4
A Housing module	4
B Power module Warrior 400i and 500i, 380 - 460 V	6
C User interface Warrior 400i and 500i	10
D Mains module Warrior 400i and 500i, 380 - 460V	10
E IPS module Warrior 400i and 500i, 380 - 460V	10
F Control module Warrior 400i and 500i	12
G Secondary connection Warrior 400i and 500i	12
H Primary inverter	14
J Secondary rectifier	14

SPARE PARTS

A Housing module

Item	Qty	Ordering no.	Denomination	Notes	Component designation
A1	1	0465 375 880	Side panel, left		
A2	1	0465 375 881	Side panel, right		
A3	2	0465 293 002	Handle corner part		
A4	2	0465 293 001	Handle corner part		
A5	1	0465 196 001	Top panel		
A6	4	0465 415 001	Foot		
A7	1	0465 331 001	Rubber mat		
A9	4		Washer BRB	12×6.4×1.5	
A10	4		Screw IN6	M6×30	
A11	1	0194 069 003	Grommet	D 37 mm	
A12	18		Screw MRT	M16×16 black	
A14	3		Screw RX-PT	8 -16×20	
A15	4		Screw RTS	ST3.5, 5×9,5	
A16	2		Screw REMFORM TORX	5×16	
A17	2		Screw MRT	M3×8	

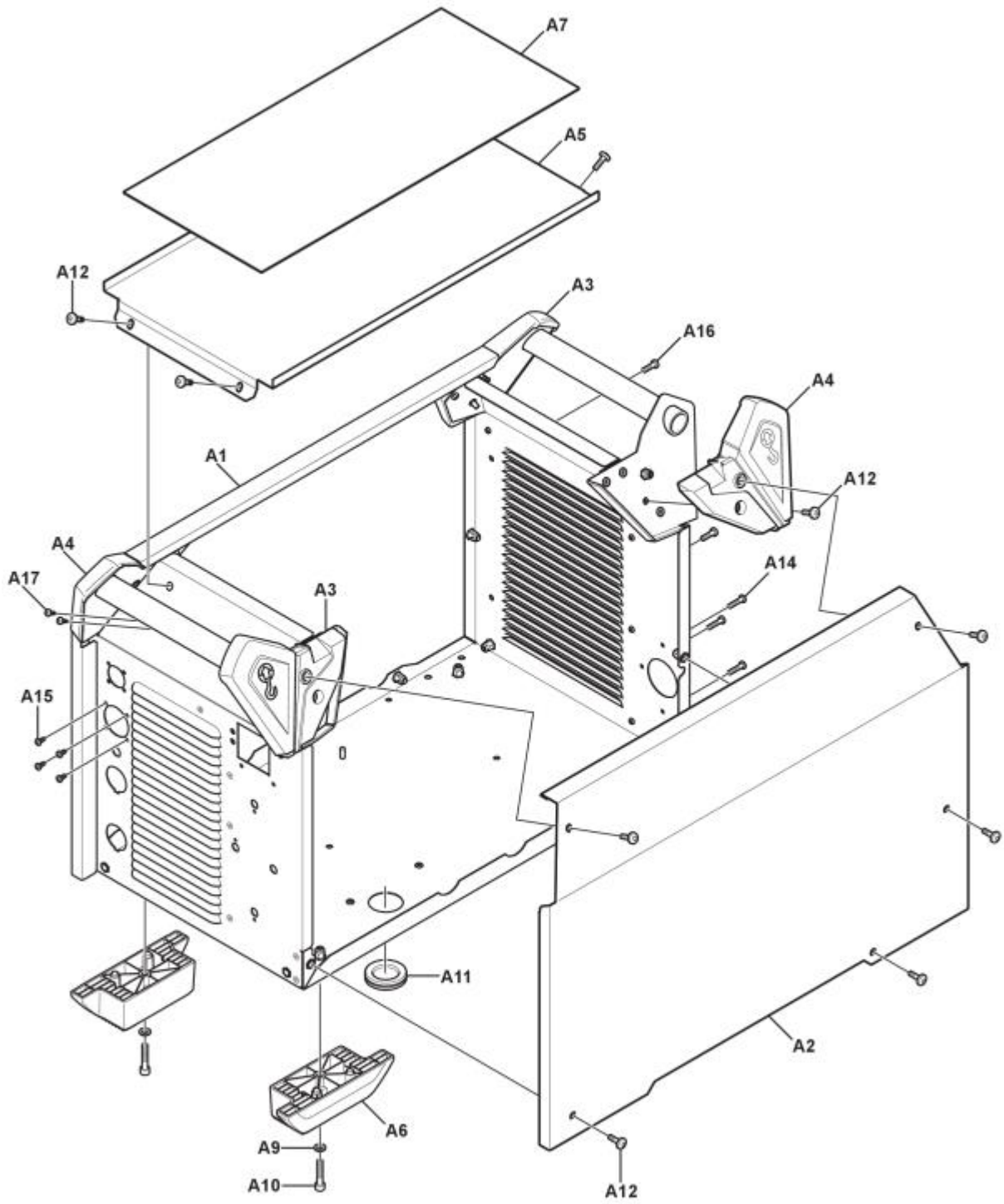

B Power module Warrior 400i and 500i, 380 - 460 V

Item	Qty	Ordering no.	Denomination	Notes	Component designation
B1	1	0465 302 880	Transformer, complete	Warrior 400i and 500i, 380-460V	15T1
B2	1	0465 311 880	Inductor, complete		15L1
B3	1	0440 003 882	PCBA Power board	Same circuit board for all units	15AP1
B4	1	0465 287 880	Secondary rectifier harness		
B5	1	0465 344 001	Fan		15EV1
B6	8	0455 569 006	Ferrite ring core	Core torodial amorphous	15L2 to 15L9
B7	1	0465 487 003	Air baffle fan		
B8	1	0465 367 880	Louver front IP, Assembly		
B9	1	0458 063 001	Current sensor	500 A	15CS1
B11	1	0465 332 001	Fan louver bracket		
B12	19		Screw MRT	M5×8, DIN7985	
B13	5		Screw MRT	M4×8, DIN7985	
B14	4		Screw MRT	M5×12, DiN7985	
B15	4		Screw		
B16	6		Screw MRT COMBI	M6×16	
B17	2		Screw M6S	M8×25	
B18	1		Screw Remform TORX	M5×16	
B19	5		Screw RTS	ST4, 2×13	
B20	4		Screw RTS	ST4, 8×13	
B21	1		Nut	M8-8-A2K	
B22	1		Nut	M5-8-A2K	
B23	4		Washer BRB Steel	D10/5, 3×1	
B24	4		Washer BRB	12×6, 4×1.5	
B25	2		Washer BRB	16/8, 4×1.5	
B26	4		Spring washer FBH	D11.8/6	
B27	1		Locking washer AZ	D10/5.3	
B28	4		Cup spring 16	16×8.2 T=0.9	
B29	6		Spacer	28.6 mm	
B30	7		Spacer screw	M4×15	
B31	13		Screw MRT COMBI	M5×10	
B32	1	0440 046 880	PCBA capacitor board		15AP2
B33	1	0465 450 001	Cap board insulation		

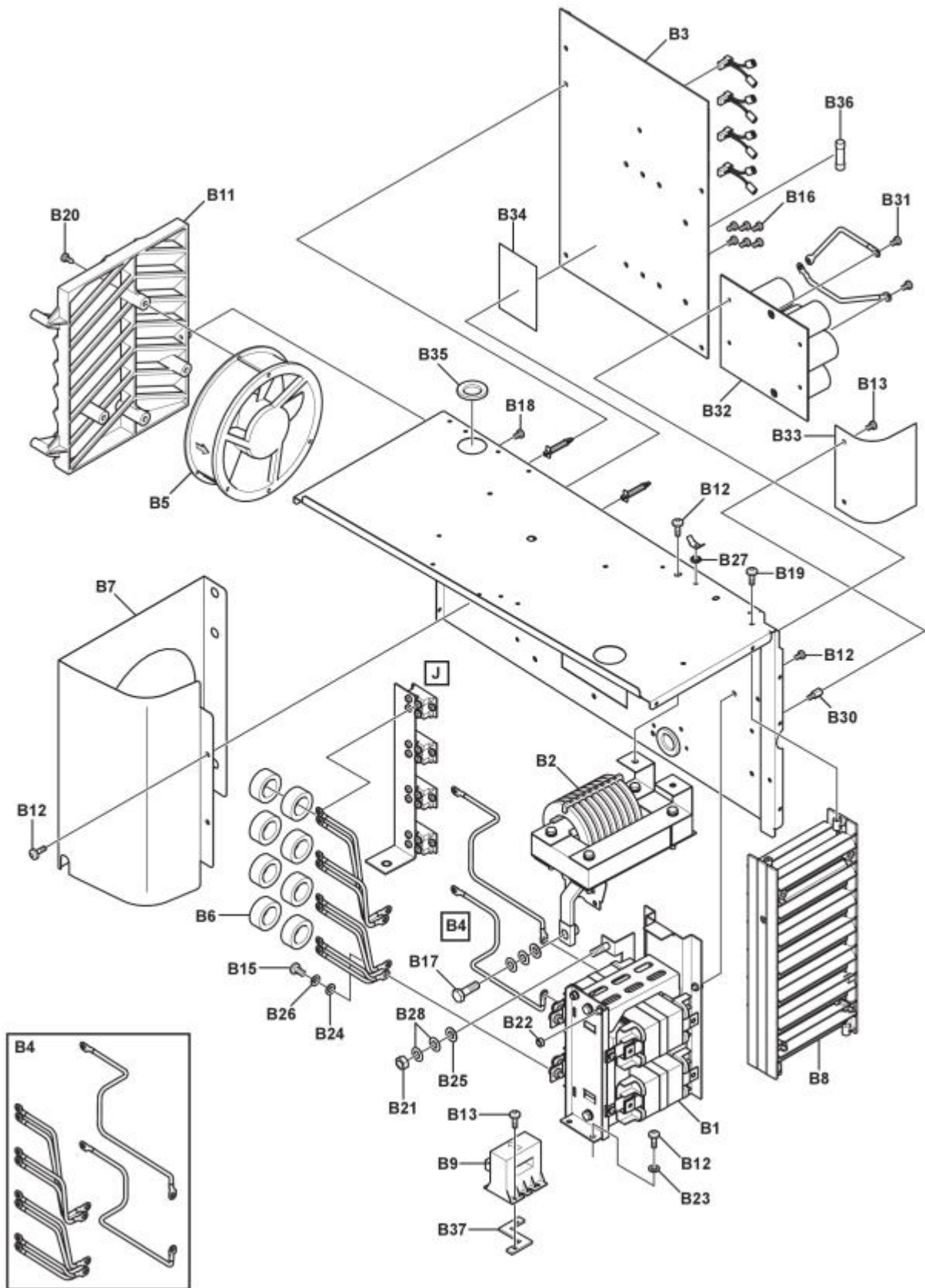

SPARE PARTS

Item	Qty	Ordering no.	Denomination	Notes	Component designation
B34	1	0465 496 001	Thermal protection insulation		
B35	4	0194 069 002	Grommet	D 28 mm	
B36	1	0194 399 120	Fuse	600 V, 5 A S3	
B37	1	0465 588 001	Current sensor distance		

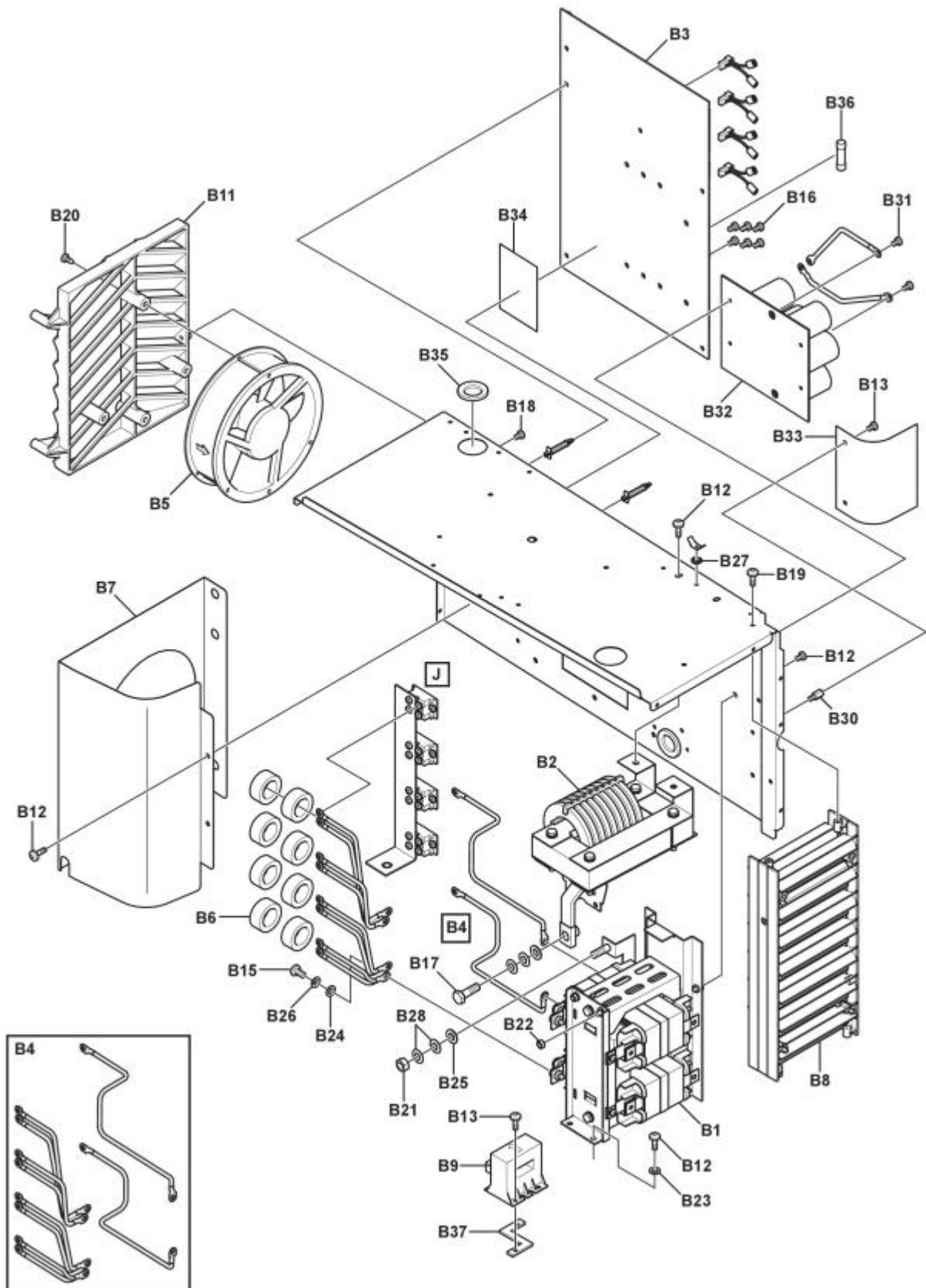

C User interface Warrior 400i and 500i

Item	Qty	Ordering no.	Denomination	Notes	Component designation
C1	1	0440 008 880	PCBA display board		1AP1
C2	1	0465 326 880	User interface harness PS1		
C3	1	0465 327 880	Encoder assembly		1G1
C4	1	0321 475 893	Knob	D36-1/4"	
C5	3		Spacer screw	M4×12	
C6	3	0321 475 881	Knob		
C7	1	0465 414 001	Front decal	W 500i	
C7	1	0465 413 001	Front decal	W 400i	
C8	3		Nut M6M 4		
C9	2		Locking washer	10, 5×18	
C10	3		Spacer screw	M4×5	

D Mains module Warrior 400i and 500i, 380 - 460V

Item	Qty	Ordering no.	Denomination	Notes	Component designation
D1	1	0440 018 880	PCBA mains filter PS1		2AP1
D2	1	0465 354 001	Main switch		2QF1
D3	1	0465 354 002	Knob for main switch		
D4	1	0469 950 880	Strain relief		
D5	1		Nut M6M	M6	
D6	1		Washer lock	6.4×11 S	
D8	1		Spacer screw	M5×18	
D9	1		Screw MRT	DIN7985 M4×8	
D10	2		Washer	Cable MSG KB6.5	
D11	2		Screw	M6×70	
D12	1	0465 354 003	Main switch gasket		
D13	1	0460 118 002	Inductor		
D14	2	0194 034 003	Ring core ferrite		
D15	1	0349 312 063	Ring core ferrite		

E IPS module Warrior 400i and 500i, 380 - 460V

Item	Qty	Ordering no.	Denomination	Notes	Component designation
E1	1	0465 323 001	Auxiliary transformer	W 400i & W 500i, 380-460 V	2T1
E2	1		Screw M6S	M8×65	

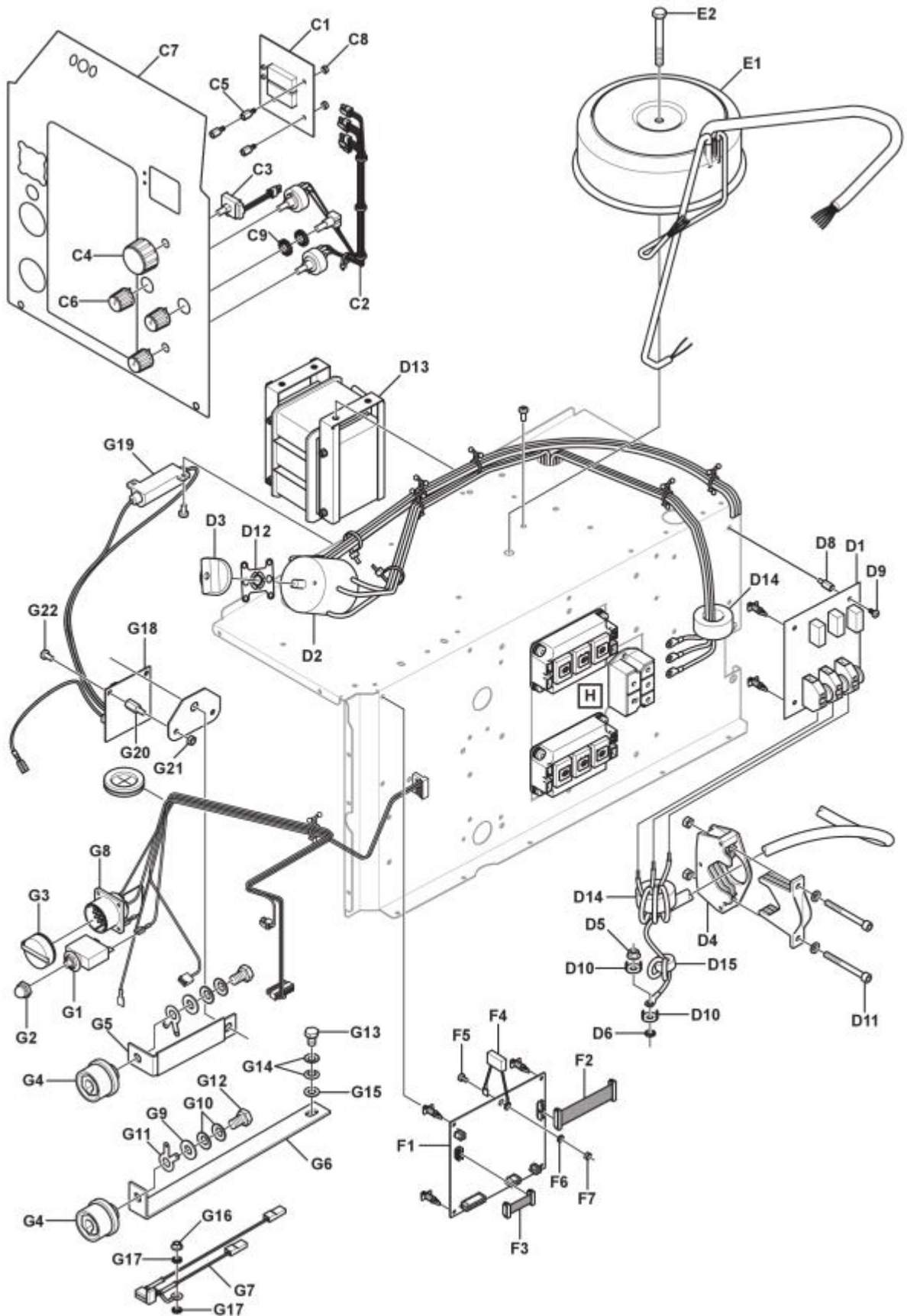

F Control module Warrior 400i and 500i

Item	Qty	Ordering no.	Denomination	Notes	Component designation
F1	1	0487 969 882	PC board control VRD	400 A	20AP1
F1	1	0487 969 883	PC board control VRD	500 A	20AP1
F2	1	0465 329 880	Flat cable w connector	20-pol	7001
F3	1	0465 349 880	Flat cable w connector	12-pol	7002
F4	1	0467 911 888	Capacitor		20C1
F5	1		Screw MRT	DIN7985 M4×8	
F6	1		Washer lock AZ	4.3×8 ST	
F7	1		Nut M6M 4		

G Secondary connection Warrior 400i and 500i

Item	Qty	Ordering no.	Denomination	Notes	Component designation
G1	1	0193 586 102	Automatic fuse	10 A	15FU1
G2	1	0455 376 001	Protection cap		
G3	1	0465 501 001	Protection cap		
G4	2	0160 362 881	Machine contact OKC	50 mm ²	XS1, XS2
G5	1	0465 309 001	Rail	Inductor to OKC	
G6	1	0465 307 001	Rail	Sec diodes to OKC	
G7	1	0463 082 880	Capacitor, complete		
G8	1	0538 500 204	Sleeve contact		
G9	2		Washer BRB		
G10	4		Cup spring	20/10.2 T=1.1	
G11	3		Flat pin connector	M10 6.3×0.8	
G12	2		Screw M6S	M10×16	
G13	1		Screw M6S	M8×12	
G14	2		Cup spring	16×8.2 T=0.9	
G15	1		Washer BRB	16/8, 4×1.5	
G16	1		Nut M6MF-8	FZB M5	
G17	2		Washer lock	D10/5.3	
G18	1		Filter board		15AP3
G19	1		Resistor	50 W	15R1
G20	2		Distance screw	M4×19	
G21	2		Nut	M4	
G22	2		Screw	M4×8	
G23	1	0465 606 880	VRD Kit	Consists of G18, G19, G20, G21 and G22	

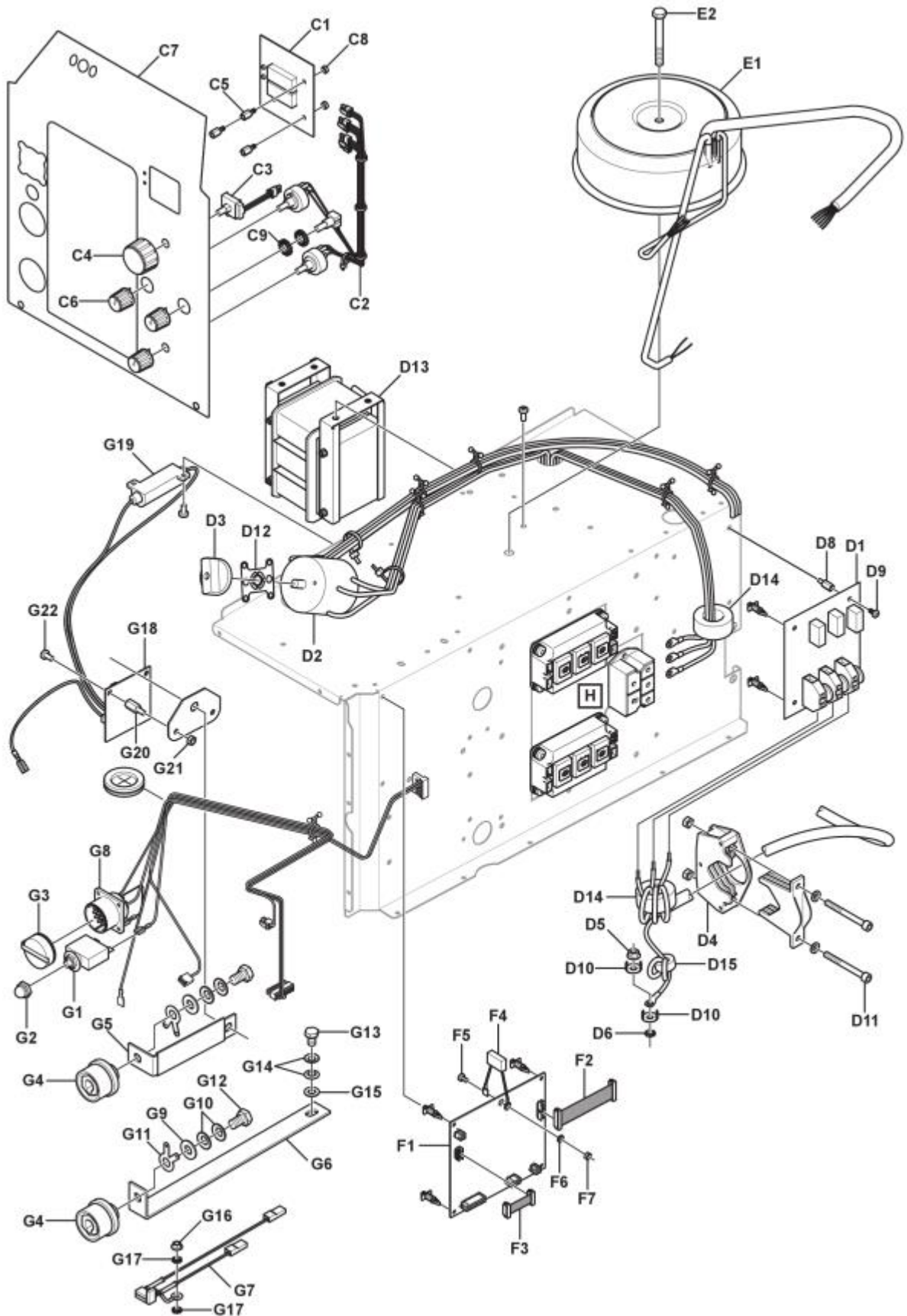

H Primary inverter

Item	Qty	Ordering no.	Denomination	Notes	Component designation
H1	1	0464 503 880	IGBT module set	Includes 2 IGBT modules, 1 thermal protection insulation, 1 thermal compound and 8 screws M6×20	15PM1, 15PM2
H2	1	0467 864 006	Thermostat		15ST2
H3	1	0464 504 880	Rectifier set	Includes 1 rectifier bridge, 1 thermal compound and 2 screws M5×12	15BR1
H4	8		Screw MRT COMBI	M6×20	
H5	2		Screw MRT COMBI	M5×12	

J Secondary rectifier

Item	Qty	Ordering no.	Denomination	Notes	Component designation
J1	1	0464 505 880	Diode set	Includes 4 diodes, 1 thermal compound, 8 screws M4×8 and 8 cup springs D8/4×0.4	15PM3 to 15PM6
J2	1	0467 864 006	Thermostat		15ST3
J3	1	0465 308 001	Rail, sec diodes		
J4	2		Washer lock	D10/5.3	
J5	1		Nut M6MF-8	M5	
J6	1		Screw MRT	DIN7985 M5×8	
J7	8		Screw MRT	DIN7985 M4×8	
J8	8		Cup spring	D8/4×0.4	

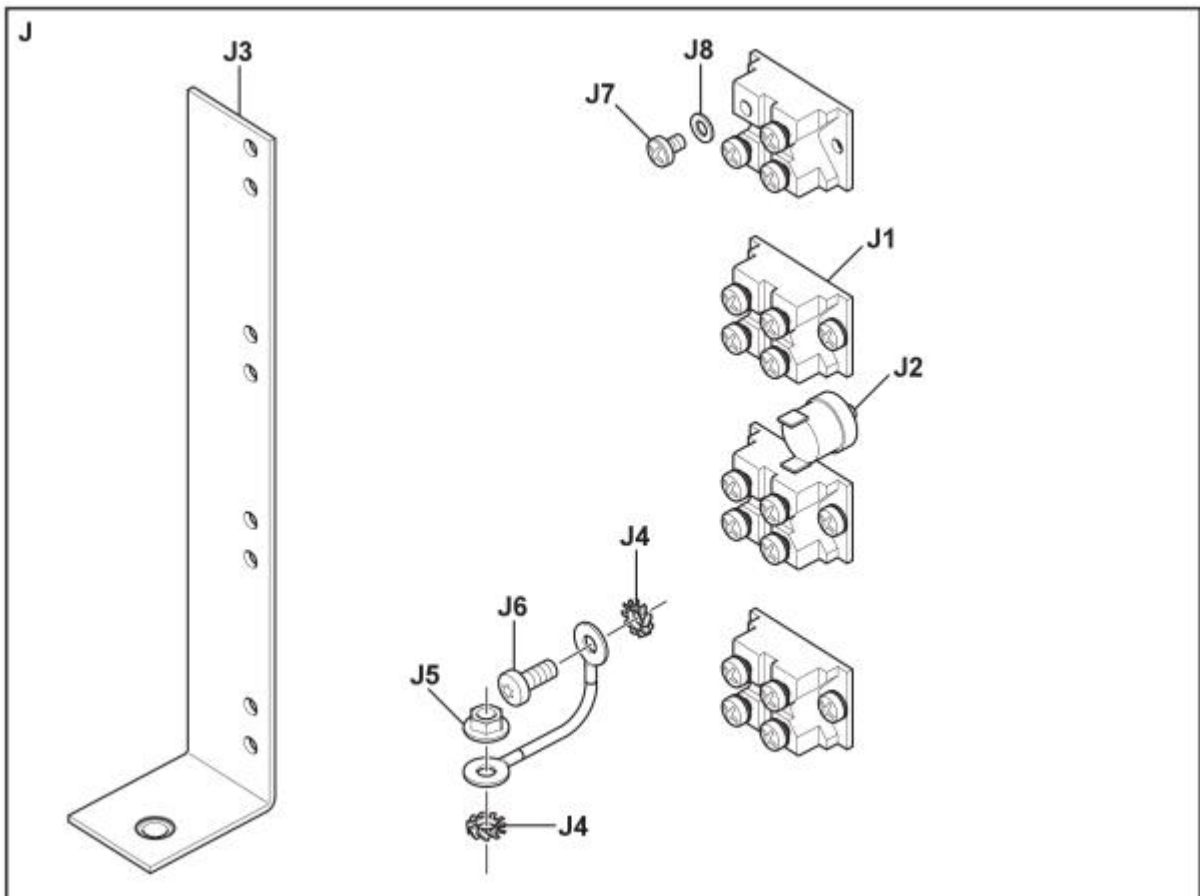
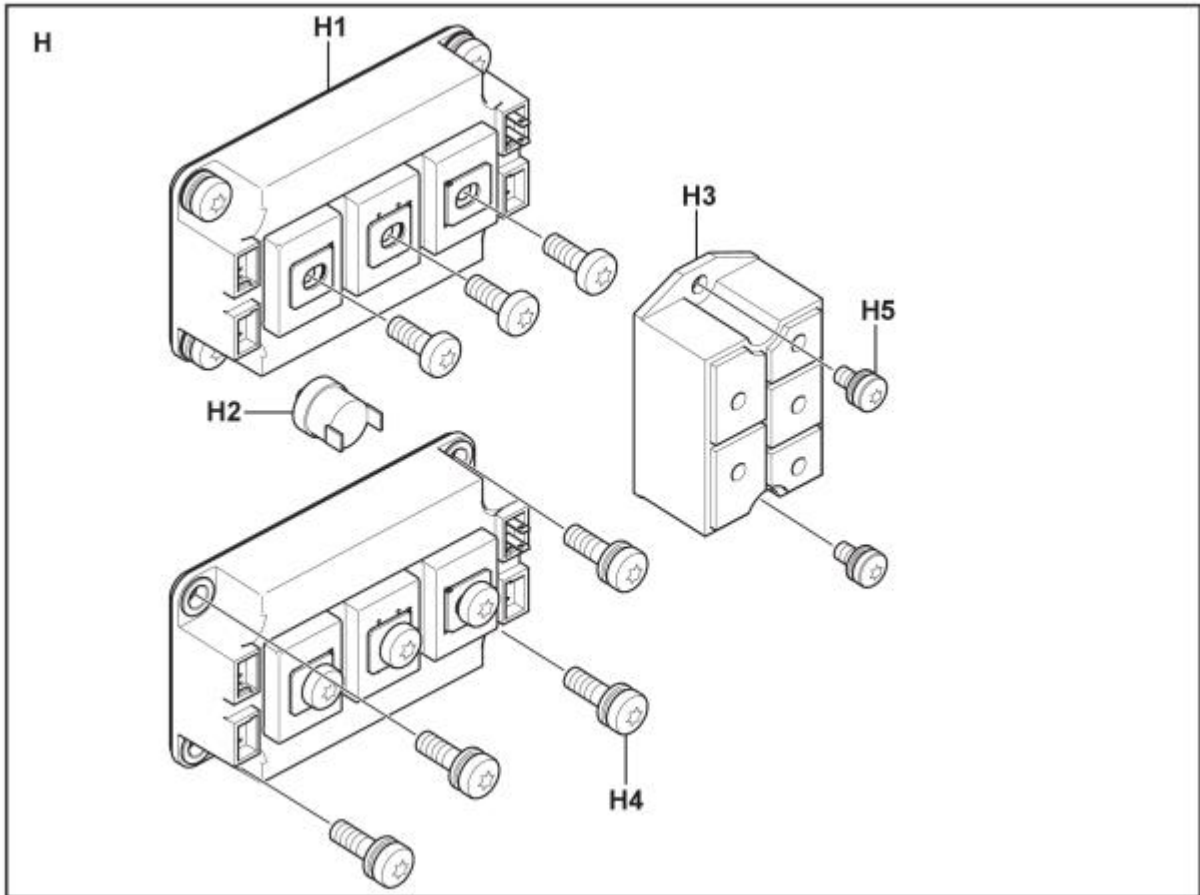

ESAB subsidiaries and representative offices

Europe

AUSTRIA

ESAB Ges.m.b.H
Vienna-Liesing
Tel: +43 1 888 25 11
Fax: +43 1 888 25 11 85

BELGIUM

S.A. ESAB N.V.
Heist-op-den-Berg
Tel: +32 15 25 79 30
Fax: +32 15 25 79 44

BULGARIA

ESAB Kft Representative Office
Sofia
Tel: +359 2 974 42 88
Fax: +359 2 974 42 88

THE CZECH REPUBLIC

ESAB VAMBERK s.r.o.
Vamberk
Tel: +420 2 819 40 885
Fax: +420 2 819 40 120

DENMARK

Aktieselskabet ESAB
Herlev
Tel: +45 36 30 01 11
Fax: +45 36 30 40 03

FINLAND

ESAB Oy
Helsinki
Tel: +358 9 547 761
Fax: +358 9 547 77 71

GREAT BRITAIN

ESAB Group (UK) Ltd
Waltham Cross
Tel: +44 1992 76 85 15
Fax: +44 1992 71 58 03

ESAB Automation Ltd
Andover
Tel: +44 1264 33 22 33
Fax: +44 1264 33 20 74

FRANCE

ESAB France S.A.
Cergy Pontoise
Tel: +33 1 30 75 55 00
Fax: +33 1 30 75 55 24

GERMANY

ESAB GmbH
Solingen
Tel: +49 212 298 0
Fax: +49 212 298 218

HUNGARY

ESAB Kft
Budapest
Tel: +36 1 20 44 182
Fax: +36 1 20 44 186

ITALY

ESAB Saldatura S.p.A.
Bareggio (Mi)
Tel: +39 02 97 96 8.1
Fax: +39 02 97 96 87 01

THE NETHERLANDS

ESAB Nederland B.V.
Amersfoort
Tel: +31 33 422 35 55
Fax: +31 33 422 35 44

NORWAY

AS ESAB
Larvik
Tel: +47 33 12 10 00
Fax: +47 33 11 52 03

POLAND

ESAB Sp.zo.o.
Katowice
Tel: +48 32 351 11 00
Fax: +48 32 351 11 20

PORTUGAL

ESAB Lda
Lisbon
Tel: +351 8 310 960
Fax: +351 1 859 1277

ROMANIA

ESAB Romania Trading SRL
Bucharest
Tel: +40 316 900 600
Fax: +40 316 900 601

RUSSIA

LLC ESAB
Moscow
Tel: +7 (495) 663 20 08
Fax: +7 (495) 663 20 09

SLOVAKIA

ESAB Slovakia s.r.o.
Bratislava
Tel: +421 7 44 88 24 26
Fax: +421 7 44 88 87 41

SPAIN

ESAB Ibérica S.A.
Alcalá de Henares (MADRID)
Tel: +34 91 878 3600
Fax: +34 91 802 3461

SWEDEN

ESAB Sverige AB
Gothenburg
Tel: +46 31 50 95 00
Fax: +46 31 50 92 22

ESAB International AB

Gothenburg
Tel: +46 31 50 90 00
Fax: +46 31 50 93 60

SWITZERLAND

ESAB AG
Dietikon
Tel: +41 1 741 25 25
Fax: +41 1 740 30 55

UKRAINE

ESAB Ukraine LLC
Kiev
Tel: +38 (044) 501 23 24
Fax: +38 (044) 575 21 88

North and South America

ARGENTINA

CONARCO
Buenos Aires
Tel: +54 11 4 753 4039
Fax: +54 11 4 753 6313

BRAZIL

ESAB S.A.
Contagem-MG
Tel: +55 31 2191 4333
Fax: +55 31 2191 4440

CANADA

ESAB Group Canada Inc.
Mississauga, Ontario
Tel: +1 905 670 02 20
Fax: +1 905 670 48 79

MEXICO

ESAB Mexico S.A.
Monterrey
Tel: +52 8 350 5959
Fax: +52 8 350 7554

USA

ESAB Welding & Cutting
Products
Florence, SC
Tel: +1 843 669 44 11
Fax: +1 843 664 57 48

Asia/Pacific

AUSTRALIA

ESAB South Pacific
Archerfield BC QLD 4108
Tel: +61 1300 372 228
Fax: +61 7 3711 2328

CHINA

Shanghai ESAB A/P
Shanghai
Tel: +86 21 2326 3000
Fax: +86 21 6566 6622

INDIA

ESAB India Ltd
Calcutta
Tel: +91 33 478 45 17
Fax: +91 33 468 18 80

INDONESIA

P.T. ESABindo Pratama
Jakarta
Tel: +62 21 460 0188
Fax: +62 21 461 2929

JAPAN

ESAB Japan
Tokyo
Tel: +81 45 670 7073
Fax: +81 45 670 7001

MALAYSIA

ESAB (Malaysia) Snd Bhd
USJ
Tel: +603 8023 7835
Fax: +603 8023 0225

SINGAPORE

ESAB Asia/Pacific Pte Ltd
Singapore
Tel: +65 6861 43 22
Fax: +65 6861 31 95

SOUTH KOREA

ESAB SeAH Corporation
Kyungnam
Tel: +82 55 269 8170
Fax: +82 55 289 8864

UNITED ARAB EMIRATES

ESAB Middle East FZE
Dubai
Tel: +971 4 887 21 11
Fax: +971 4 887 22 63

Africa

EGYPT

ESAB Egypt
Dokki-Cairo
Tel: +20 2 390 96 69
Fax: +20 2 393 32 13

SOUTH AFRICA

ESAB Africa Welding & Cutting
Ltd
Durbanville 7570 - Cape Town
Tel: +27 (0)21 975 8924

Distributors

For addresses and phone numbers to our distributors in other countries, please visit our home page

www.esab.com



www.esab.com

